

*Pump Station Component List for
VTS under 350gpm*

- A - Diesel Engine (Liquid or Air Cooled) w/
Murphy Automatic Shut Down
- B - Exhaust Primer
- C - Steel Frame on Skids
- D - Clutch Assembly
- E - Drive Shaft w/ Shield
- F - Frame Mount Pump w/ Packing Gland Seal
- G - Eccentric Connection
- H - Suction Pipe w/ Flange or Coupler
(Galvanized Steel)
- I - Pressure Gauge w/ Pressure Loss Shut Down
on Murphy System
- J - Priming Valve
- K - Pressure Pipe (Galvanized Steel, 11 gauge)
- L - Pressure Relief Valve
- M - In Line Pressure Filter (Flange Mount)

Engine and Pump Specification

Pipe and Filter Specification

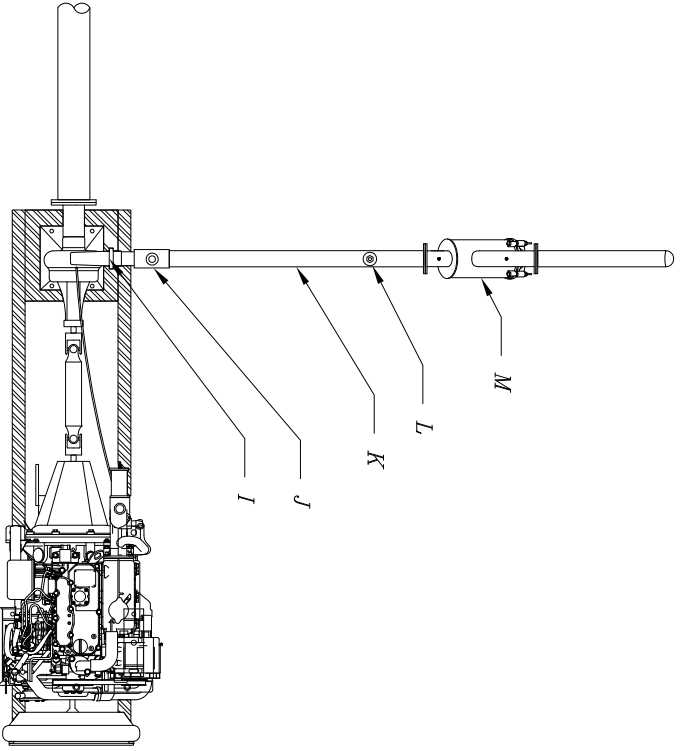

UNL-BSE52

DIESEL PUMP STANDARD DRAWING

Drawn by: JGROSS 2/10

Designed by:

Approved by: